



Alarm lamp - VIS-LED

Visual warning signal lamp

Short facts:

- Long-lasting LED illumination technology
- Bright and visible
- Wall-mount
- Ideal for aquaculture and industrial applications

Recognizing warning signals with one view - The VIS-LED.

The SENECT Alarm lamp VIS-LED can be connected to the actuator ports of SENECT control units and therefore be used to give the user an visual alarm signal.

The bright LEDs show an optimal visibility also at daylight conditions in combination with a long lifetime. With its IP65 ingress protection, the LED-VIS is also suitable for outdoor applications.

Technical Information	
Dimensions	Ø 61,8 mm x 62,8 mm
Material	PC, MPPO
Temperature range	-25°C to +70°C
Power consumption	1.2 W
Cable length	5 m
Compatibility	with all SENECT Control units
Protection class	IP65

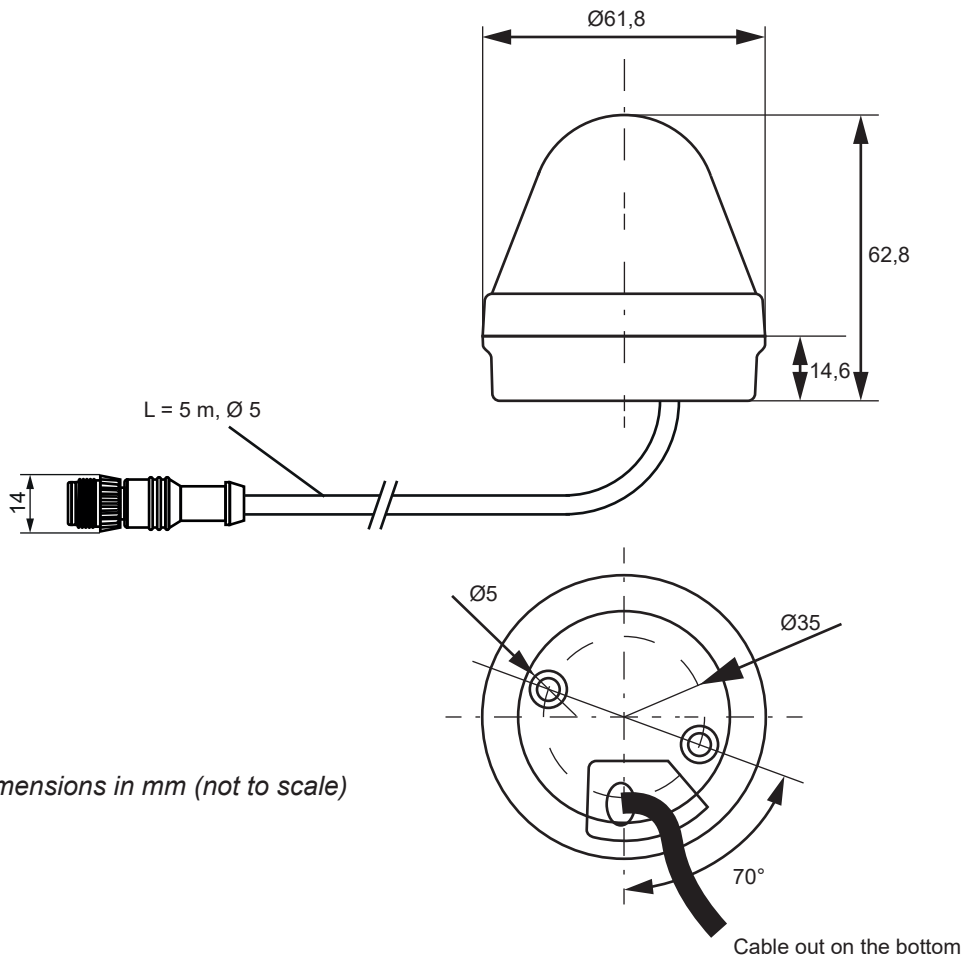

VIS-LED 001-002 EN Version: 1.0 Status: released, subject to alterations

Art.-No.	Item	Scope of delivery
3200	Alarm lamp VIS-LED	Alarm lamp, manual