

Solenoid Valve Water M12 Brass valve G1“

Short facts:

- Robust brass valve
- Normally closed
- 0,2 up to 12 bar operating pressure
- Ideal for aquaculture applications

Always enough water - Refilling with the solenoid valve M12.

The SENECT solenoid valve water M12 is designed for the use in the water supply line. It is used to refill water to compensate deficiencies.

Due to its brass body, the solenoid valve can be operated with a pressure of up to 12 bar.

Technical information	
Dimensions	93 (length) x 113 x 73 mm
Material	Brass, sealing EPDM
Connection	G1“ inner thread
Temperature range	0°C up to +90°C
Power consumption	typ. 10 W
Cable length	5 m
Compatibility	with all SENECT control units
Ingress protection	IP 67

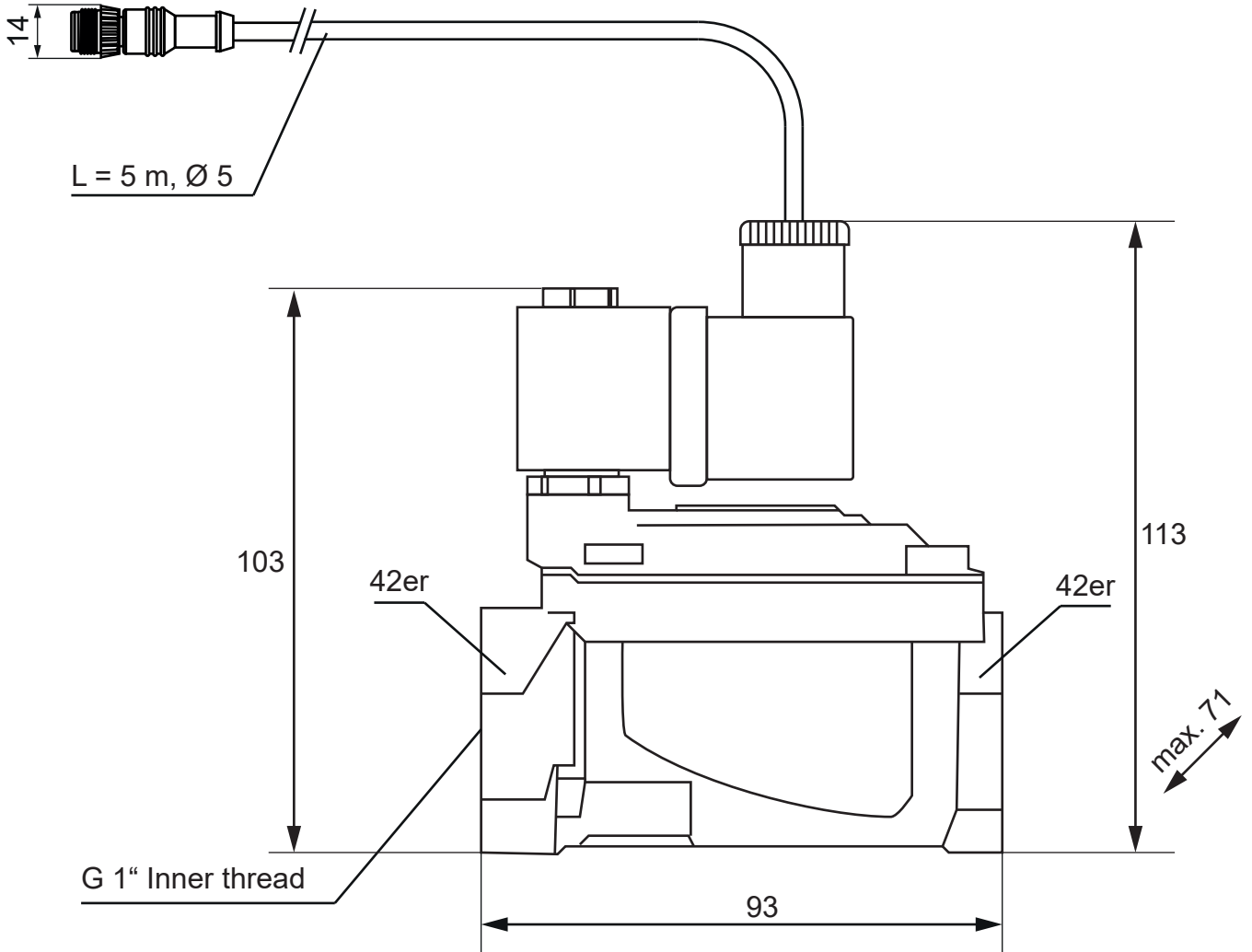

Dimensions in mm (not to scale)

Flow direction (marked by an arrow on the bottom)

Art.-No.	Item	Scope of delivery
3010	Solenoid valve water M12	Valve incl. 5 m cable, manual

MVW-M12-SC 001-002 EN Version: 1.0 Status: released, subject to alterations